

STEAM GENERATORS

**GMT
MODEL**

The horizontal **GMT** and vertical **GMT/V** steam generators are once-through coil boilers. The exchange of heat between water, steam and combustion products, the relative turbulent regimes, the fluid velocities kept as constant as possible by varying the passage sections, allow to obtain a particularly effective thermal exchange.

The thermal load in the combustion chamber is on average below 2,000,000 calories per cubic meter, the specific production (kg of steam per square meter of heated surface) does not reach 70 Kg/sqm.

For installations in Italy, the GMT and GMT / V generators up to size 200 are excluded from the field of application of the UNI-TS 11325 and are exempted from the continuous presence of the licensed driver according to article 29 of the D.M. 05/21/1974. For higher sizes it is possible to provide the configuration suitable for operation without supervision for 72 hours. If necessary, for example in the case of installation of European countries other than Italy, this configuration can also be provided on smaller models.

Maximum power in minimal space, very compact design, high performance, are the peculiar characteristics of these generators that can work both with two flame burners and with modulated regulation.

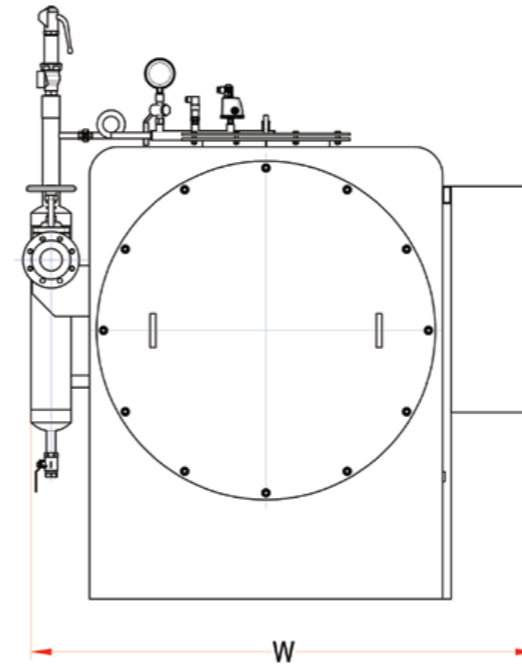

PRODUCT

- Once-through coil steam generators, horizontal or vertical

TYOLOGY

- Once-through coil steam generators • Horizontal or vertical • 3 passes

CAPACITY

- 120 kg/h – 8,000 kg/h

TECHNICAL DATA FORCED CIRCULATION STEAM GENERATORS OPERATION WITHOUT CONTINUOUS SUPERVISION FOR 72 HOURS

GMT HORIZONTAL

TYPE		GMT 12	GMT 20	GMT 30	GMT 40	GMT 50	GMT 60	GMT 80	GMT 100	GMT 120	GMT 150
Steam production	kg/h	120	200	300	400	500	600	800	1,000	1,200	1,500
	kg/h (from and at)	133	222	333	444	556	667	889	1,111	1,333	1,667
Capacity	lb/h	294	490	735	980	1,224	1,469	1,959	2,449	2,939	3,673
	kcal/h	72,000	120,000	180,000	240,000	300,000	360,000	480,000	600,000	720,000	900,000
	kW	84	140	209	279	349	419	558	698	837	1,047
Design pressure	Btu/h	285,707	476,179	714,268	952,357	1,190,447	1,428,536	1,904,715	2,380,894	2,857,072	3,571,340
	HP	112	187	281	374	468	561	749	936	1,123	1,404
Efficiency without economizer	bar	11.76	11.76	11.76	11.76	11.76	11.76	11.76	11.76	11.76	11.76
	psi	171	171	171	171	171	171	171	171	171	171
Efficiency with economizer	% ±1	93.0	92.0	91.0	91.0	90.0	91.0	91.0	90.0	89.0	90.0
Water content	% ±1	96.0	95.0	94.0	94.0	93.0	94.0	94.0	93.0	92.0	93.0
Furnace pressure drop	liters	27	27	27	38	38	72	84	124	124	194
Installation length (burner excluded)	mm H2O	20	20	30	35	35	40	40	70	90	80
Installation length (burner included)	mm	1,750	1,750	1,750	1,750	1,750	2,300	2,300	2,300	2,300	3,350
Installation width	mm	2,300	2,300	2,300	2,300	2,300	2,900	2,900	2,900	2,900	4,150
Installation height	mm	1,500	1,500	1,500	1,500	1,500	1,500	1,500	1,500	1,500	1,700
Empty weight (burner excluded)	mm	1,650	1,650	1,650	1,650	1,650	1,700	1,700	1,750	1,750	2,000
	kg	750	750	750	850	850	1,100	1,100	1,250	1,250	1,800



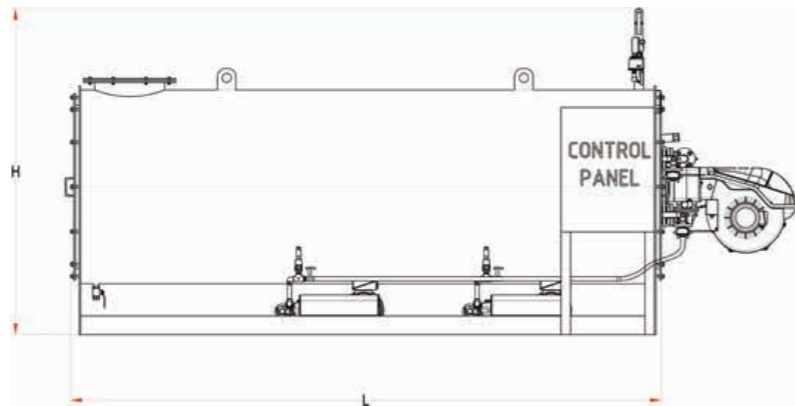

TECHNICAL DATA FORCED CIRCULATION STEAM GENERATORS OPERATION WITHOUT CONTINUOUS SUPERVISION FOR 72 HOURS						GMT HORIZONTAL				
TYPE		GMT 180	GMT 200	GMT 250	GMT 300	GMT 400	GMT 500	GMT 600	GMT 700	GMT 800
Steam production	kg/h	1,800	2,000	2,500	3,000	4,000	5,000	6,000	7,000	8,000
Steam production (from and at)	kg/h	2,000	2,222	2,778	3,333	4,444	5,556	6,667	7,778	8,889
	lb/h	4,408	4,898	6,122	7,347	9,796	12,244	14,693	17,142	19,591
Capacity	kcal/h	1,080,000	1,200,000	1,500,000	1,800,000	2,400,000	3,000,000	3,600,000	4,200,000	4,800,000
	kW	1,256	1,396	1,745	2,093	2,791	3,489	4,187	4,885	5,582
	Btu/h	4,285,608	4,761,787	5,952,234	7,142,681	9,523,574	11,904,468	14,285,362	16,666,255	19,047,149
	HP	1,684	1,871	2,339	2,807	3,743	4,679	5,614	6,550	7,486
Design pressure	bar	11.76	11.76	11.76	11.76	12.00	12.00	12.00	12.00	12.00
	psi	171	171	171	171	174	174	174	174	174
Efficiency without economizer	% ±1	90.0	89.0	90.0	89.0	89.0	90.0	90.0	90.0	90.0
Efficiency with economizer	% ±1	93.0	92.0	93.0	92.0	92.0	93.0	93.0	93.0	93.0
Water content	liters	250	250	250	250	570	899	1,095	1,250	1,196
Furnace pressure drop	mm H2O	80	80	90	90	100	110	115	120	125
Installation length (burner excluded)	mm	3,350	3,350	3,700	4,100	4,400	4,750	5,150	5,400	5,550
Installation length (burner included)	mm	4,150	4,150	4,800	5,200	5,750	5,850	6,300	6,600	6,800
Installation width	mm	1,700	1,700	1,850	1,850	2,200	2,550	2,500	3,200	3,200
Installation height	mm	2,100	2,100	2,100	2,200	2,200	2,700	2,600	2,500	2,500
Empty weight (burner excluded)	kg	2,100	2,100	2,900	3,000	3,850	6,600	7,000	7,700	9,000

TECHNICAL DATA FORCED CIRCULATION STEAM GENERATORS OPERATION WITHOUT CONTINUOUS SUPERVISION FOR 72 HOURS							GMT VERTICAL				
TYPE		GMT/V 12	GMT/V 20	GMT/V 30	GMT/V 40	GMT/V 50	GMT/V 60	GMT/V 80	GMT/V 100	GMT/V 120	GMT/V 150
Steam production	kg/h	120	200	300	400	500	600	800	1,000	1,200	1,500
Steam production (from and at)	kg/h	133	222	333	444	556	667	889	1,111	1,333	1,667
	lb/h	294	490	735	980	1,224	1,469	1,959	2,449	2,939	3,673
Capacity	kcal/h	72,000	120,000	180,000	240,000	300,000	360,000	480,000	600,000	720,000	900,000
	kW	84	140	209	279	349	419	558	698	837	1,047
	Btu/h	285,707	476,179	714,268	952,357	1,190,447	1,428,536	1,904,715	2,380,894	2,857,072	3,571,340
	HP	112	187	281	374	468	561	749	936	1,123	1,404
Design pressure	bar	11.76	11.76	11.76	11.76	11.76	11.76	11.76	11.76	11.76	11.76
	psi	171	171	171	171	171	171	171	171	171	171
Efficiency without economizer	% ±1	93.0	92.0	91.0	91.0	90.0	91.0	91.0	90.0	89.0	90.0
Efficiency with economizer	% ±1	96.0	95.0	94.0	94.0	93.0	94.0	94.0	93.0	92.0	93.0
Water content	liters	27	27	27	38	38	72	84	124	124	194
Furnace pressure drop	mm H2O	20	20	30	35	35	40	40	70	90	80
Installation width	mm	1,000	1,000	1,000	1,000	1,000	1,250	1,250	1,250	1,250	1,550
Installation depth	mm	1,375	1,375	1,375	1,250	1,250	1,500	1,500	1,550	1,550	1,650
Installation height (burner excluded)	mm	2,050	2,050	2,050	2,050	2,050	2,050	2,200	2,600	2,600	3,100
Empty weight (burner excluded)	kg	700	700	700	750	750	1,050	1,100	1,250	1,250	1,800

TECHNICAL DATA FORCED CIRCULATION STEAM GENERATORS OPERATION WITHOUT CONTINUOUS SUPERVISION FOR 72 HOURS						GMT VERTICAL				
TYPE		GMT/V 180	GMT/V 200	GMT/V 250	GMT/V 300	GMT/V 400	GMT/V 500	GMT/V 600	GMT/V 700	GMT/V 800
Steam production	kg/h	1,800	2,000	2,500	3,000	4,000	5,000	6,000	7,000	8,000
Steam production (from and at)	kg/h	2,000	2,222	2,778	3,333	4,444	5,556	6,667	7,778	8,889
	lb/h	4,408	4,898	6,122	7,347	9,796	12,244	14,693	17,142	19,591
Capacity	kcal/h	1,080,000	1,200,000	1,500,000	1,800,000	2,400,000	3,000,000	3,600,000	4,200,000	4,800,000
	kW	1,256	1,396	1,745	2,093	2,791	3,489	4,187	4,885	5,582
	Btu/h	4,285,608	4,761,787	5,952,234	7,142,681	9,523,574	11,904,468	14,285,362	16,666,255	19,047,149
	HP	1,684	1,871	2,339	2,807	3,743	4,679	5,614	6,550	7,486
Design pressure	bar	11.76	11.76	11.76	11.76	12.00	12.00	12.00	12.00	12.00
	psi	171	171	171	171	174	174	174	174	174
Efficiency without economizer	% ±1	90.0	89.0	90.0	89.0	89.0	90.0	90.0	90.0	90.0
Efficiency with economizer	% ±1	93.0	92.0	93.0	92.0	92.0	93.0	93.0	93.0	93.0
Water content	liters	250	250	250	250	570	899	1,095	1,250	1,196
Furnace pressure drop	mm H2O	80	80	90	90	100	110	115	120	125
Installation width	mm	1,600	1,600	1,700	1,700	2,000	2,450	2,450	2,900	2,900
Installation depth	mm	1,700	1,700	1,600	1,600	1,850	2,150	2,150	2,600	2,600
Installation height (burner excluded)	mm	3,350	3,350	3,800	4,050	4,300	5,000	5,250	5,800	5,800
Empty weight (burner excluded)	kg	1,800	1,800	2,700	2,800	3,800	6,200	6,300	7,700	9,000

